

Attaching the Vacuum Pickup DLP7400

※Applicable screwdriver : DLV30 / DLV45 / DLV70 Series

(1) Attach a bit and insert the enclosed spacer to the screwdriver.

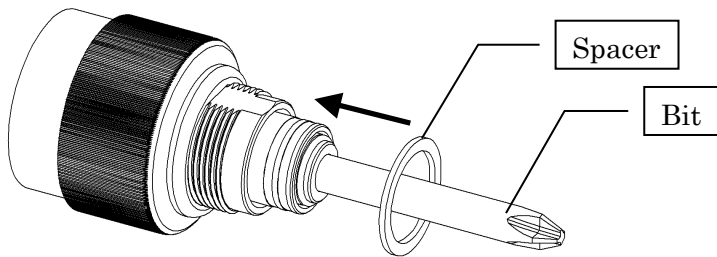

(2) Fix the Vacuum Pickup onto the screwdriver by turning it clockwise.

⚠ CAUTION

— Check that the spacer is inserted.

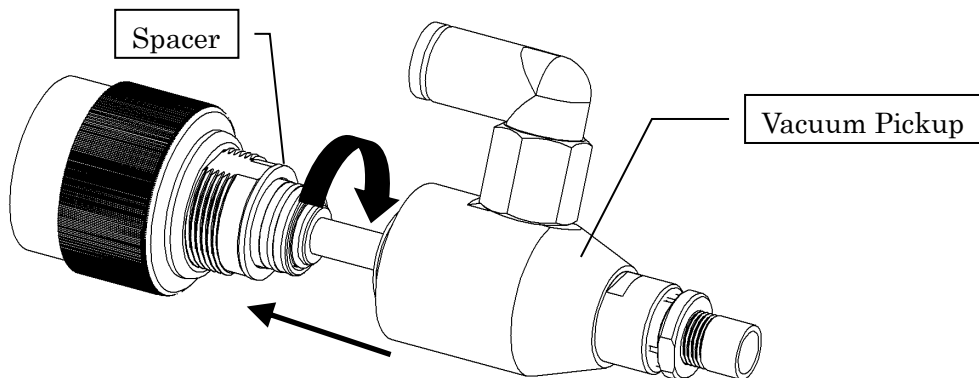

(3) Adjust the sleeve length according to the conditions of use.

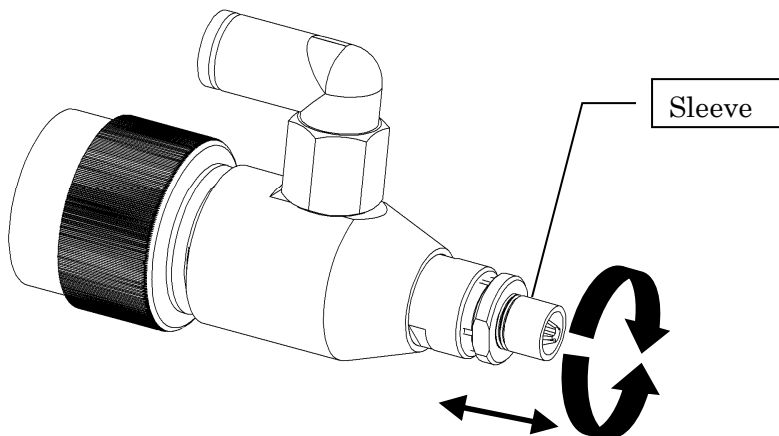

- (4) Fix the Chuck to the Moving Sleeve using the enclosed two spanners.
After they are fixed, make sure that the sleeve does not rotate.

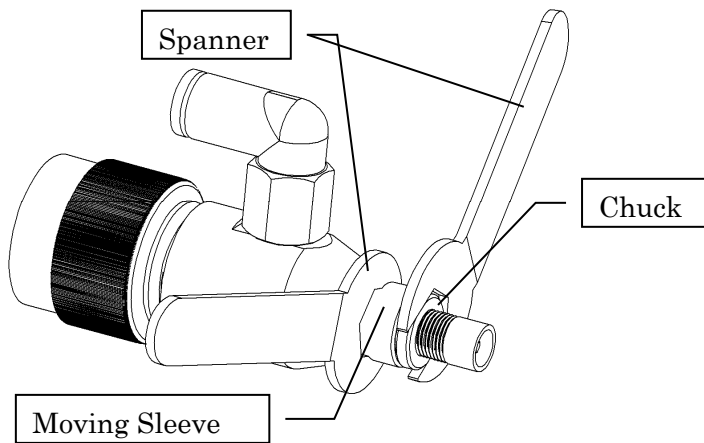

- (5) Applicable tube diameter : 6DIA(0.24")